

1979-04 MM Standard Torque-arm (MMTA-1 & -2)



The ultimate rear suspension for your Mustang is now available from Maximum Motorsports. Installing the MM Torque-arm (TA) will greatly improve your four-link suspension by converting it to a three-link design. Your car will have vastly improved traction, both in a straight line and when exiting corners. Your car will be much more stable and predictable, and you can get on the throttle sooner and harder while accelerating out of a corner.

In the stock four-link design, the rear upper control arms are trying to do two jobs at once. One is to control axle wind-up, the other is to locate the axle side to side. When pushed to the performance limit, the upper control arms don't do either job very well. Our TA suspension system separates the functions of the suspension components—each component has only one job, and is designed to perform that one function with no compromises. The MM TA controls axle rotation much better than the upper control arms. In addition, the Panhard Bar has the sole job of locating the axle side to side, which it also does better than the upper control arms. The lower control arms primarily have the job of thrusting the car forward under acceleration. The MM TA suspension system allows complete removal of the rear upper control arms and the quad shocks. The resulting three-link design will articulate freely, even during extreme cornering, acceleration and braking.

The free-moving three-link design has so much more traction that the grip at the front of the car will now be the limiting factor (understeer). You must raise the rear spring rate to increase the rear roll resistance, which takes some cornering load off the front. To meet your needs, Maximum Motorsports has determined the rear spring to match your front spring rate (see Spring Rate Table). These selected rear springs will give you better handling and improved ride quality with your MM TA suspension system.

When we sat down to design our TA we listened to what our customers wanted. The three issues we heard mentioned time and again were concerns about ground clearance, exhaust clearance, and access to the differential cover. You talked, we listened! Compared to other TA's, Maximum Motorsports' has greater ground clearance, nearly one inch more exhaust clearance, and allows complete access to the differential cover.

The MM TA fits 1979-2004 Mustangs with an 8.8" axle (except for 1999-2004 Cobra with IRS). Use MMTA-1 for rectangular tube subframe connectors, or MMTA-2 for round tube subframe connectors. The difference is the brackets that weld to the subframe connectors.

Our Standard TA is rated for engine torque levels up to 590 lb-ft depending on the differential gear ratio (see Engine Torque Table).

Engine Torque Table		
Differential Ratio	Standard TA Max. Engine Torque (lb-ft)	Heavy Duty TA Max. Engine Torque (lb-ft)
4.56:1	300	475
4.30:1	330	510
4.08:1	355	550
3.73:1	400	620
3.55:1	425	660
3.27:1	475	725
3.08:1	515	790
2.73:1	590	900

Rear Lower Control Arm Recommendations

To get the best performance from your free-moving TA suspension system, you need rear lower control arms that don't cause suspension bind. Suspension bind keeps the rear axle from moving freely. When there is any suspension movement, the control arms not only pivot about their mounting bolts, they also move sideways in an angular motion. If that angular motion is restricted because of a poor bushing design, the suspension will bind up (not want to move). That binding increases the wheel rate, which in turn causes unpredictable performance as well as increased stress on the torque boxes. Bind is prevented by using rear lower control arm bushings that allow a slight sideways angular motion. Control arm designs that do not allow enough angular motion include those with

hard urethane bushings at both ends, solid metal bushings at either end, or solid plastic bushings at either end (Delrin/Nylon).

Subframe Connector Requirements

Your car must have suitable welded in Subframe Connectors installed **before** installing the Maximum Motorsports TA. Bolt-on connectors do not attach securely enough to the chassis. The following minimum dimensions must be met to make sure your subframe connectors are strong enough to support the load from the MM TA.

Subframe Connector Minimum Required Dimensions	
Rectangular	1.00" x 2.00" x 0.120" Wall
Rectangular	1.25" x 2.00" x 0.083" Wall
Rectangular	1.50" x 1.50" x 0.083" Wall
Round	1.50" x 0.120" Wall

Lateral Location Requirements

Your car must have a sturdy Panhard Bar or Watt's Link installed **before** installing the Maximum Motorsports TA. It is **YOUR** responsibility to determine the suitability of any device other than ours. *You* are responsible for the consequences if you do not use a strong enough locating device.

Spring Recommendations

Use the following chart to determine the proper springs to run with your TA. For customers running front coil-over spring rates of 350 lb/in and above, please contact your sales person for the proper rear spring.

Spring Recommendations	
Front Spring Rate (lb/in)	Rear Spring Part #
490-575	H&R 51561
575-800	H&R 51650.99
800-900	MM 42TA5
900+	MM 43TA7
Coil-over 175-250	MM 42TA5
Coil-over 250-325	MM 43TA7
Coil-over 350+	Coil-over Recommended

Exhaust Requirements

- It may be necessary to relocate the H-pipe downwards slightly. We have measured a plus or minus 1/2" tolerance in the up and down location of the exhaust system. It must be in the half of the range that puts it farther away from the bottom of the car. This can easily be accomplished by giving a firm tug on the H-pipe while it is disconnected from the mufflers and hanging from the transmission hangers. Make

sure that the H-pipe is loosened from the headers to avoid stressing the headers.

- It may be necessary to slightly grind the exhaust flanges to provide clearance for the TA Crossmember, especially with aftermarket exhaust systems.
- The attachment bolts for the exhaust flanges may need to be shortened (simply cut off any excess threads).
- Some aftermarket H-pipes position the cross-over tube closer to the rear of the car than the stock H-pipe. If you are unfortunate enough to have one of these H-pipes, the cross-over tube will have to be cut out and moved forward to provide clearance for the TA Crossmember. It is best to have this modification performed by a competent muffler shop before attempting the installation. You will probably have interference problems if your cross-over tube is located closer than 2.25" to the front of the flange (see photo below).
- If you have a **Bassani Exhaust** system, please see Page 12 for modification techniques.

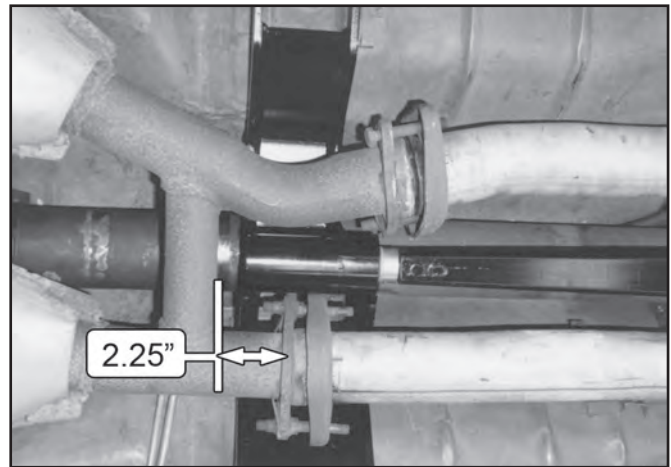

Tools Required

- 3/8" Drive Ratchet
- 1/2" Drive Ratchet
- 150+ Ft-lb Torque Wrench
- 15/16" Socket
- 9/16" Socket
- 9/16" Open End Wrench
- 14mm Socket
- 13 mm Socket
- 10 mm Socket
- Rubber Mallet
- Angle Finder
- MIG or TIG welder

Read all instructions before beginning installation!

1. Raise the car on a lift that supports the car by the tires, or jack up the car and support it firmly on jack stands. Place the stands under the rear axle (so it will be located as at ride height). Place the front jack stands on the front K-member between the pivots of the front control arms. Make sure the rear axle is not in a (body) roll situation due to the position of the jack stands. Each rear wheel must be positioned within 1/4" of ride height. To find ride height before raising the car, measure the distance from the fender lip down to the wheel. This distance should remain the same when the rear axle is supported on jackstands.
2. Remove the vibration damper from the front of the differential. Remember to pull off the bracket from the top side of the differential that the damper's retaining bolts were threaded into.



3. Remove the pinion snubber assembly from the bottom of the chassis (directly above the front of the differential). It is held in place with three small screws.



4. Clean and degrease the top and the bottom of the differential flanges where the vibration damper was bolted (typically, there is a lot of caked on dirt and grease). These flanges must be clean before attaching the TA.

5. Remove both rear upper control arms.
6. Unbolt the rear portion of the exhaust from the H-pipe. Loosen, but do not remove, the 4 bolts (2 per side) holding the H-pipe to the headers.

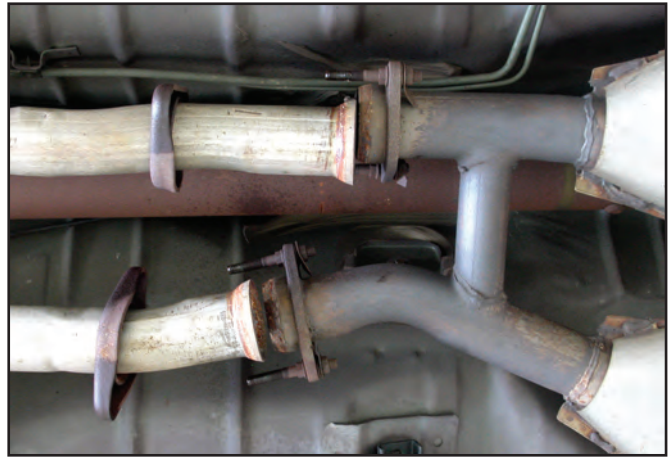

7. Remove the two nuts holding the transmission mount to the transmission crossmember. Support the transmission with a jack. Remove the two bolts holding the transmission crossmember to the chassis.



8. Lower and rotate the transmission crossmember to provide access to the two bolts holding the transmission mount to the transmission. Remove these bolts to allow the H-pipe to drop down away from the chassis during installation.

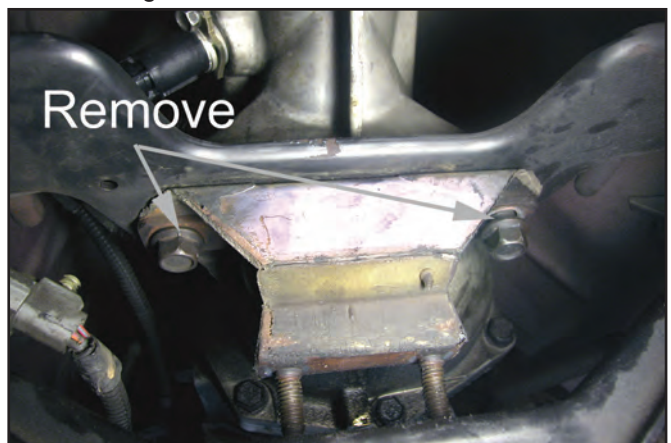

- Attach the TA to the rear axle with two U-bolts per side. Slide the U-bolts between the brake lines and the axle tube. The brake lines may need to be slightly pushed away from the axle tube and the clip on the passenger side of the axle may need to be slightly re-bent. Place a 3/8" G8 flat washer and a 3/8" Nylock nut onto the threads of the U-bolts. The U-bolts must be snug enough to draw the TA saddle mounts into firm contact with the axle tubes, but not so tight as to prevent the TA from pivoting around the axle tube during installation. The two saddle mounts should be evenly spaced from the center section of the differential. The front of the TA will be prevented from dropping down and touching the ground because the back edge of the TA will touch the differential cover flange.

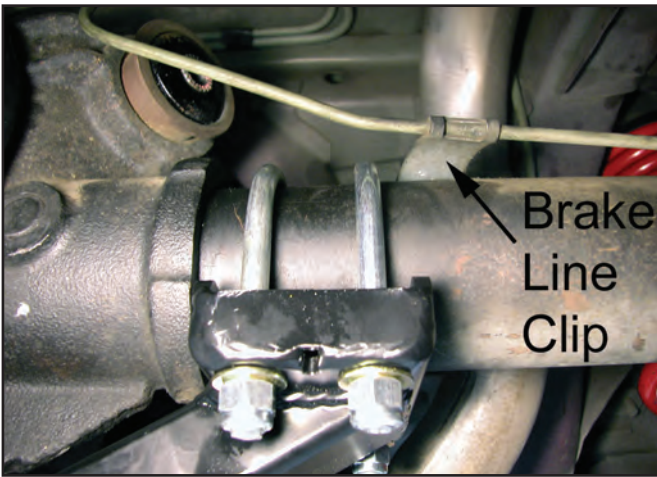
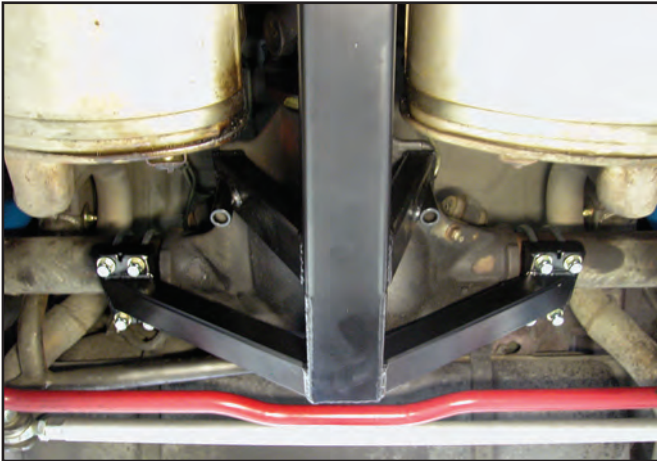

Brake Line Clip

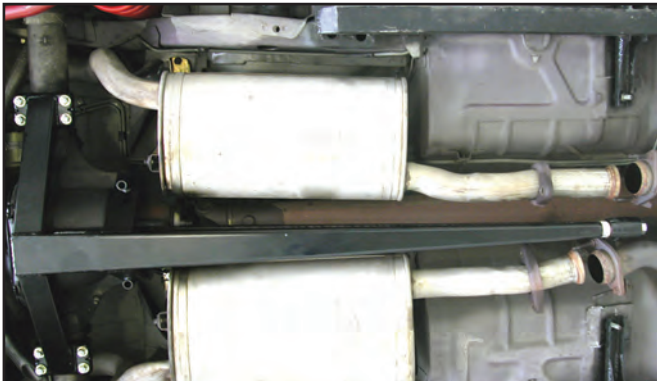

- Lightly grease the Pivot Bolt Subassembly Sleeve and the inside of the Urethane Bushings with the supplied water resistant Teflon grease. Slide the two Urethane Bushings onto the sleeve as shown. After the urethane, there must be one 5/8" G8 flat washer against the urethane on the threaded end of the bolt. After the 5/8" washer, you *must* place the 1/2" thick aluminum spacer.

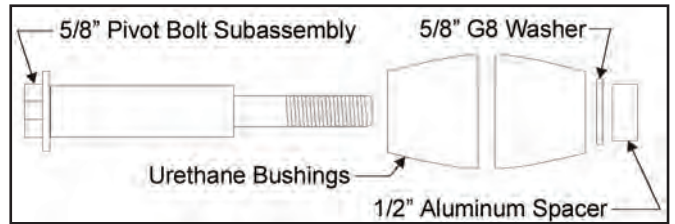

- Install the Urethane Pivot Bolt Assembly onto the front of the TA. Torque the 5/8" Pivot Bolt Assembly to 220 lb-ft. Thoroughly grease the Urethane Bushings and the inside of the Receiver Tube with the supplied water resistant Teflon grease.



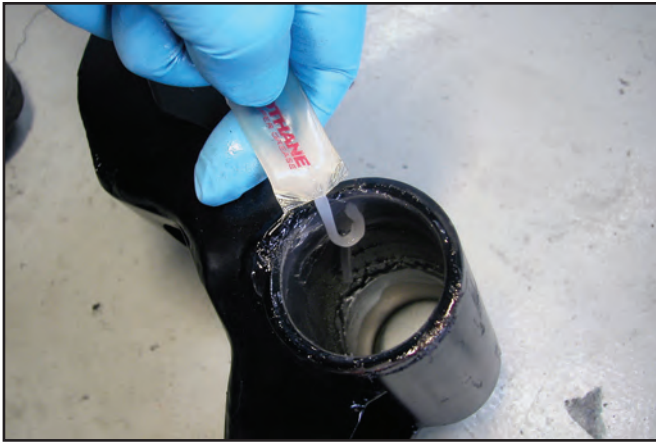

12. Bolt the Mounting Tabs to the TA Crossmember using the 3/8 X 1-1/2" bolts with one 1/4" thick flat washers under the head of each bolt (Mounting Tabs for rectangular tube subframe connectors illustrated). Also place one 1/4" thick flat washer under each 3/8" Nylock nut.



13. Slide the TA Crossmember over the top of the H-pipe.



14. The TA Crossmember may now be slid rearwards while inserting the Urethane Pivot Bolt Assembly into the TA Crossmember Receiver Tube. Due to the tight fit, a rubber mallet may be used to position the TA Crossmember rearwards on the Urethane Pivot Bolt Assembly.

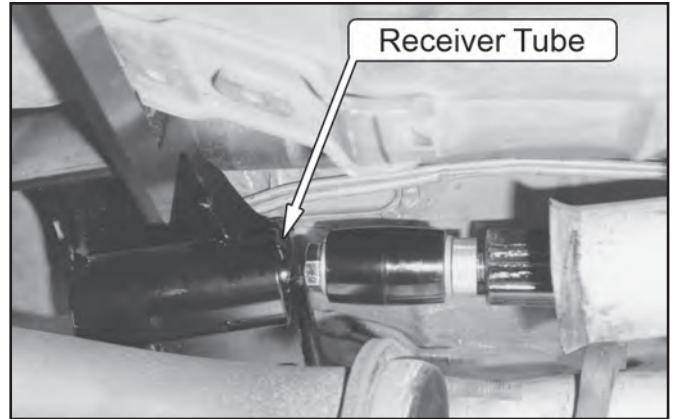

15. The rearward edge of the urethane (closest to the TA) must be flush with the rearward edge of the Receiver Tube to provide proper clearance during suspension movement, and for the grease fitting to lubricate the Urethane Bushings properly.

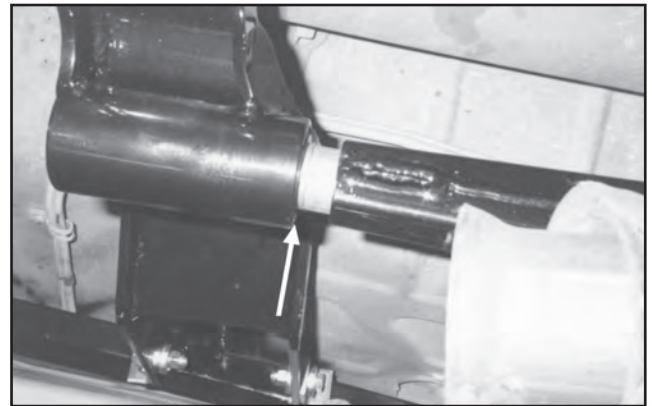

16. Raise the TA Crossmember up to the bottom of the car. The TA Crossmember needs to be positioned as close to the bottom of the chassis as possible in order to provide the most exhaust clearance. You may want to bend upwards various metal tabs which protrude down from the floorpan so the TA Crossmember will be positioned as close as possible to the floorpan. If you have rectangular tube subframe connectors you may use C-clamps or Vise Grips to clamp the Mounting Tabs to the car's subframe connectors.



17. Check that the TA Crossmember is situated squarely in the car by measuring the distance between the front edge of the TA Crossmember and the transmission crossmember flanges on each side of the car. Remember, while squaring up the TA Crossmember, keep the rear edge of the Urethane Bushing flush with the rearward edge of the Receiver Tube.

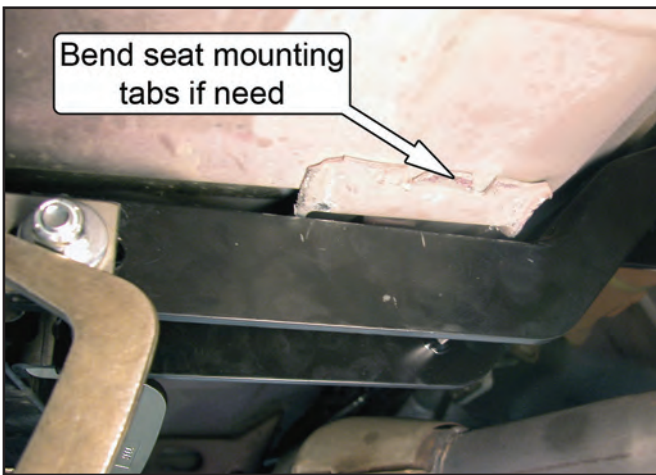

18. Trial fit the exhaust by raising the H-pipe and transmission exhaust hanger back into place. Reattach the transmission mount to the transmission.



19. Bolt the transmission crossmember to the transmission mount. Slide the bolts between the transmission crossmember and the chassis in place. Do not tighten any of the bolts right now. The whole assembly may need to be removed again. Lower the floor-jack supporting the transmission.

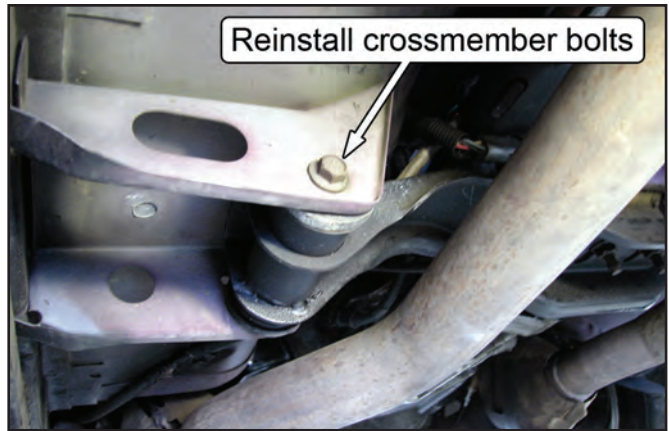

20. Reattach the intermediate tubes to the H-pipe and snug the bolts. Snug the bolts holding the H-pipe to the headers. Again, do not fully tighten all the bolts because it may be necessary to lower the H-pipe and TA Crossmember again before final fitting.



21. Check the clearance between the exhaust flanges and the TA Crossmember. The TA Crossmember is designed so that the exhaust flanges on the passenger side are positioned between the rails of the TA Crossmember. The exhaust flanges on the driver side are positioned rearward of the rails of the TA Crossmember.

This Crossmember is Located in the Best Position
(the optional 1/4" Aluminum spacer was added)

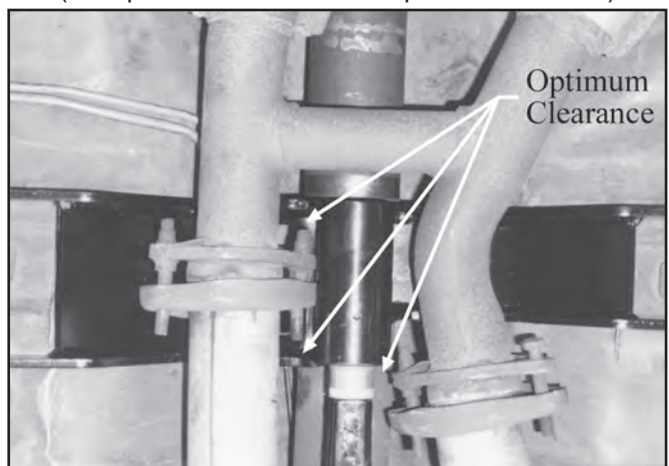

22. For ideal exhaust flange clearance, the TA Crossmember may need to be moved forward in the car. Use a combination of the optional spacers (one 1/4" aluminum spacer and three extra 5/8" G8 washers) on the pivot bolt to allow for this adjustment. To make adjustments of the TA Crossmember, the exhaust must again be lowered. Then you can slide the TA Crossmember forward over the cross-over tube of the H-pipe. Add your choice of spacers to the Pivot Bolt Assembly (this moves the Urethane Bushings closer to the front of the car). Use whatever combination of the required and optional spacers is necessary to provide the best exhaust clearance on your car. See photos for examples of flange clearance (your car will probably require a different arrangement of spacers than what is shown to adjust for optimum exhaust clearance).

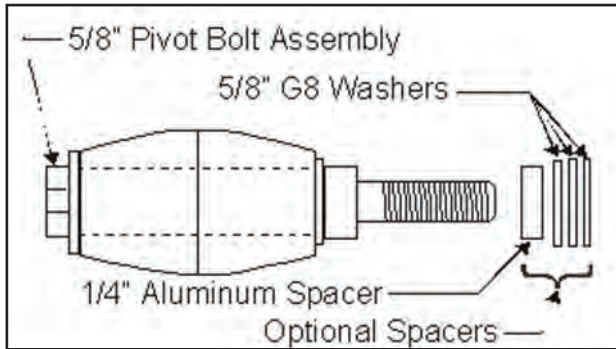

NOTE: The rearward edge of the Urethane Bushing must be flush with the rearward edge of the Receiver Tube. The alignment of the Urethane Bushing and the Receiver Tube is what determines the fore and aft position of the TA Crossmember.

This Crossmember is Located Too Far Rearward
(only the required 1/2" spacer was used)

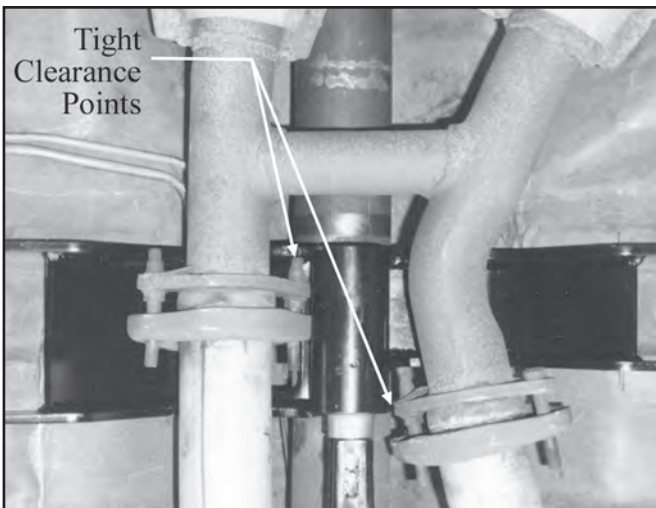

This Crossmember is Located Too Far Forward
(the optional 1/4" alum. spacer plus (3) 5/8" G8 washers were used in addition to the required 1/2" spacer)

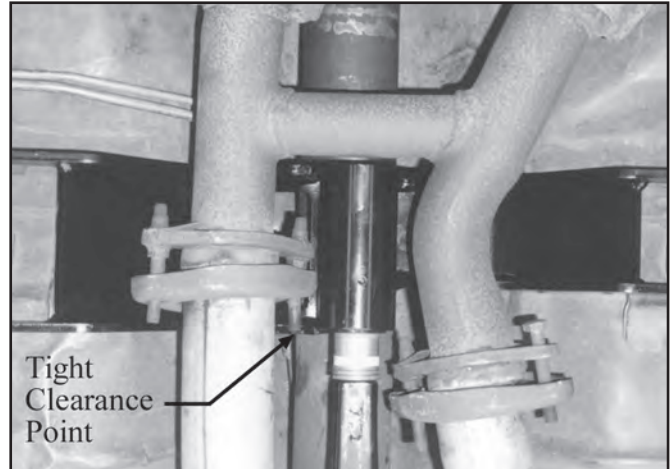

23. If you changed the spacer arrangement in Step 22, remember to torque the 5/8" Pivot Bolt Assembly to 220 lb-ft before reinstalling the Torque Arm Crossmember.
24. Raise the TA and TA Crossmember into place and mark the areas to be welded. Lower the TA and TA Crossmember and clean any paint or plating from the subframe connectors in the area to be welded. The weld area is shown below.

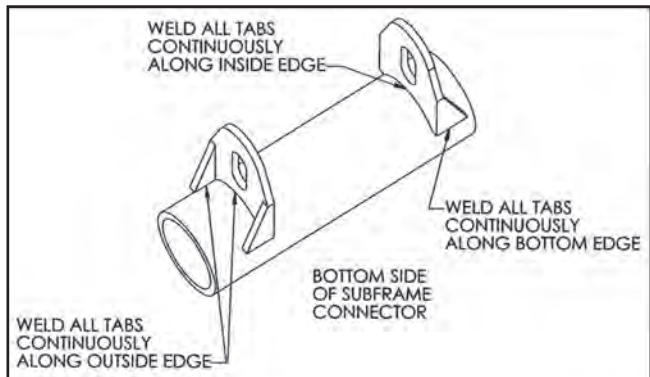
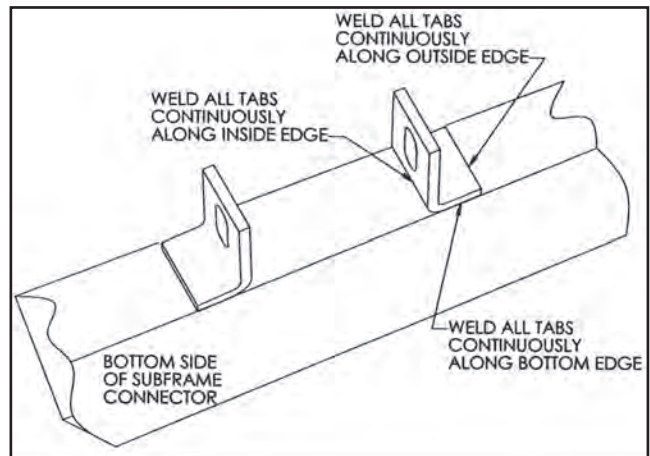

- Raise the TA and TA Crossmember into place for final welding. Remember to pay careful attention to keep the TA Crossmember square in the car, in proper relation with the Urethane Bushings, and watch the exhaust clearance.
- Use a long straight edge to make sure the Receiver Tube is parallel to the TA. Perfection is not necessary, but avoid gross misalignment.

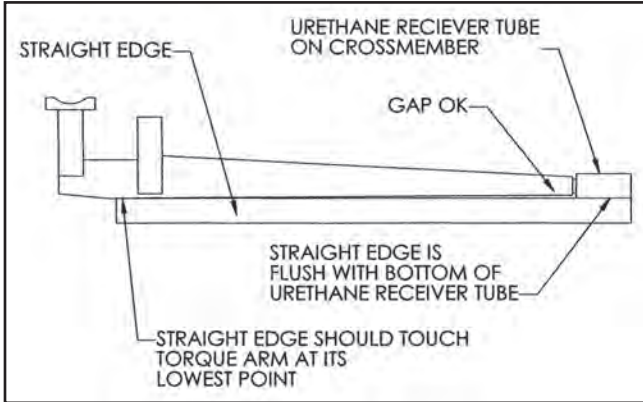

- MIG or TIG weld the Mounting Tabs to the subframe connectors.



- Check the position of the TA front mounting legs against the bottom of the differential flanges. If necessary, run a 7/16" drill bit up through the holes in the flanges, or use a hand file, to modify the holes so the 3/8" x 4-1/2" G8 mounting bolts will easily pass through the mounting holes.
- Use the appropriate number of 2" diameter shims to bridge the gap between the TA front mounting legs and the bottom of the differential flanges. The number of shims is not important at this point; this initial number of shims will create your baseline reading for further pinion angle adjustment.

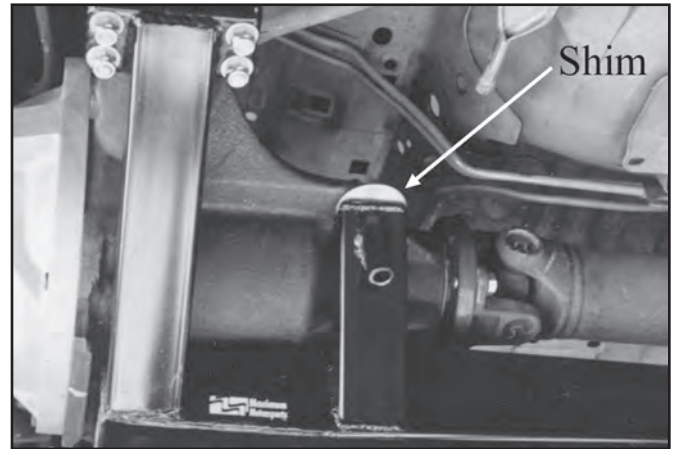

- Install one set of spherical washers (two-pieces) under the head of each 3/8" x 4-1/2" G8 bolt (thin half first - see drawing for the correct orientation). Insert each 3/8" bolt down through the differential flange, shim(s), round tube of the TA front mounting leg, spherical washer set (thick half first - see drawing), and thread on a 3/8" G8 Nylock nut. The spherical washers prevent casting irregularities and adjustments to the pinion angle from placing a bending load on the bolts. Snug the 3/8" X 4-1/2" bolts.

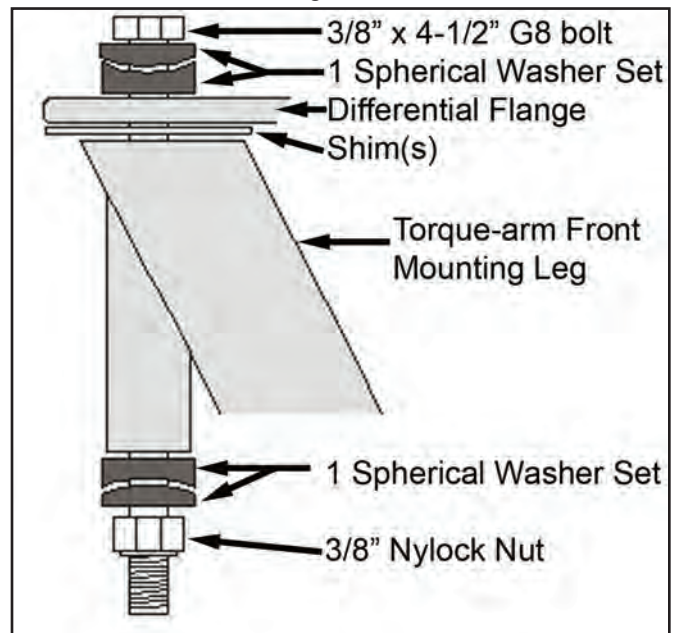

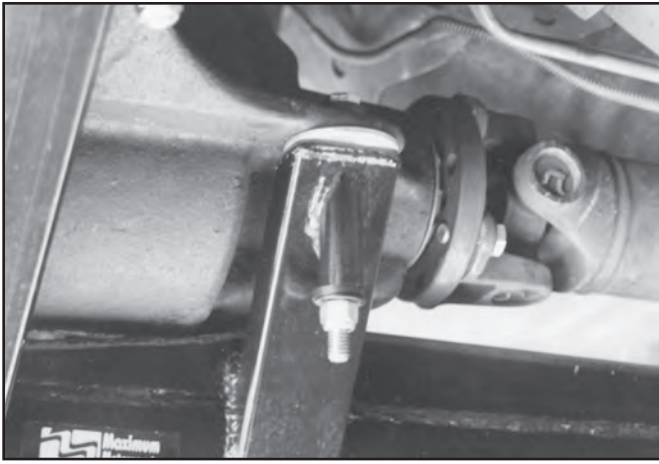

31. Measure the pinion angle. The easiest way to do this is to place an angle finder on a straight edge and place the straight edge on the driveshaft mounting flange.



32. Measure the transmission output shaft angle. The easiest way to do this is to place the angle finder on the front of the crank pulley.



33. The goal is to make the pinion angle of the differential match the transmission output shaft angle. Each 2" shim will add or subtract 1/2 degree. Do not be surprised if you have to raise the front of the differential considerably. Ford sets the pinion angle 3 to 4 degrees below the transmission output shaft angle because of axle wind up. Axle wind up is allowed by the soft rubber in the stock control arms; during acceleration the pinion angle will then come into alignment with the transmission output shaft. The TA controls axle wind up much better than the 4-link, and allows you to match the pinion angle to the transmission output shaft.

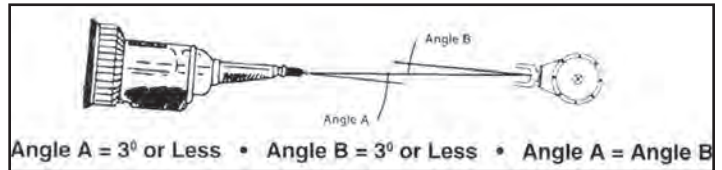

34. After you are satisfied with the pinion angle, torque the (2) 3/8" x 4-1/2" G8 bolts for the front mounting legs to 47 lb-ft. Torque the (8) 3/8" Nylock nuts on the U-bolts to 33 lb-ft. Tighten in an even pattern to avoid pulling the U-bolts over center.

35. Make sure the (4) 3/8" x 1-1/2" bolts holding the TA Crossmember to the subframes are loose. Measure the distance from the center of the Receiver Tube to the pinchweld seam (at the bottom of the rocker panel) on each side of the car. The TA Crossmember tube should be evenly placed between the seams, centering it beneath the car. If the TA Crossmember is not within +/- 1/2" of center, your rear axle is out of the normal factory tolerance, and there is a problem with your axle not being square or centered under the car.



Possible reasons for your axle not being square or centered under the car are:

- Your Panhard Rod length may not be correct.
- The control arm bushings may be deformed. Make sure they are all in good shape.
- If you have aftermarket or adjustable-length control arms, check their length. We've tested control arms from other companies that were not made to the correct length, or even the same length side to side - this will skew the axle under the car.
- Inspect your torque boxes and upper arm mounts for cracks. If there are cracks, the car has been badly stressed, and that may be the source of the problem.
- Check your lower control arm pivot bolt mounting holes. We have seen them incorrectly placed by Ford, both on the axle and on the chassis.

DO NOT attempt to force the TA Crossmember to the center of the car. This will pre-load the TA, possibly binding the control arm bushings, and will lead to inconsistent handling of your car.

36. After you are satisfied the axle is square and centered under the car, paint the TA Crossmember Mounting Tabs and torque the (4) 3/8" bolts holding the TA Crossmember to the subframe connectors to 33 lb-ft.

37. Tighten all exhaust bolts and transmission crossmember bolts.

NOTE: If you have a Bassani exhaust system and have clearance problems, see page 12 for troubleshooting options.

38. Install the Grease Fitting into the bottom of the Receiver Tube. The Grease Fitting should not be installed before this step because the airtight fit of the Urethane Bushings can make adjustment of the TA Crossmember very difficult.

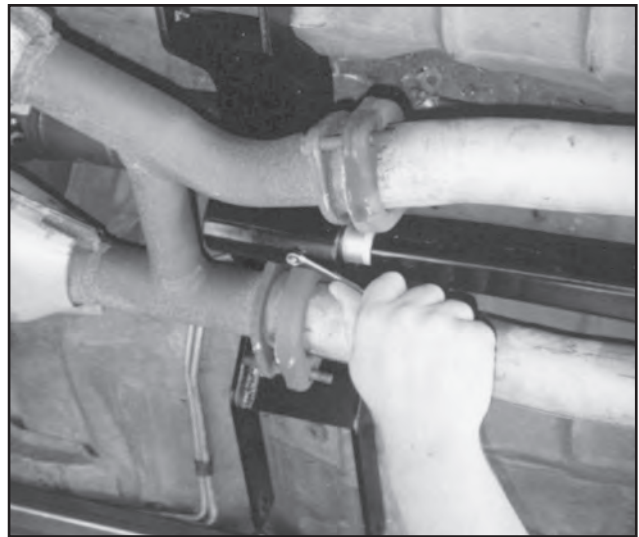

39. Remove the quad shocks. Ford put the quad shocks on your Mustang to dampen axle wind-up (which leads to wheel hop). With the TA there is no axle wind-up, so the quad shocks are unnecessary. To reduce weight you may also remove the quad shock mounting brackets and the upper control arm differential bushings.

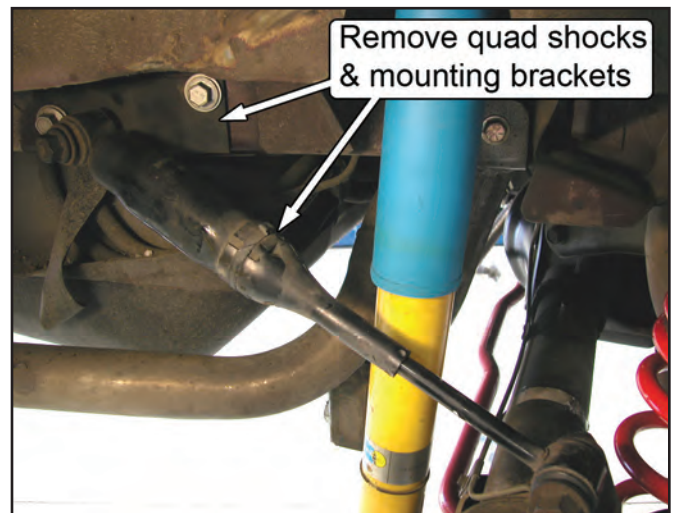

40. Because the TA is more rigidly connecting your rear suspension to the chassis, imbalance of rotating parts in the rear suspension will be more noticeable. To find the cause of vibration, first check the balance and roundness of the rear tires. Second, many Mustangs have a driveshaft that is poorly balanced; having your driveshaft professionally balanced should greatly reduce vibrations.

41. Safely lower your car to the ground and test drive.



25 lbs. of Parts off Your Car!

(2002 Mustang shown with MMTA-1)



Hardware Kit MMTA-1 Includes the Following:

- 4 3/8" x 1-1/2" Bolt
- 2 3/8" x 4-1/2" G8 Bolt
- 1 5/8" Pivot Bolt Subassembly
- 8 3/8" G8 Washer
- 4 3/8" Spherical washer set
(one thin, one thick per set)
- 8 3/8" x 1" x 1/4" Thick Flat Washer
- 8 2" dia. Shim
- 4 5/8" G8 Washer
- 12 3/8" G5 Nylock nut
- 2 3/8" G8 Nylock nut
- 4 3/8" U-bolt
- 1 1/2" Thick Steel Spacer
- 1 1/4" Thick Steel Spacer
- 2 Urethane Bushing
- 4 Mounting Tab, rectangular subframe connectors
- 1 Grease Fitting
- 1 Grease Packet

Hardware Kit MMTA-2 Includes the Following:

- 4 3/8" x 1-1/2" Bolt
- 2 3/8" x 4-1/2" G8 Bolt
- 1 5/8" Pivot Bolt Subassembly
- 8 3/8" G8 Washer
- 4 3/8" Spherical washer set
(one thin, one thick per set)
- 8 3/8" x 1" x 1/4" Thick Flat Washer
- 8 2" dia. Shim
- 4 5/8" G8 Washer
- 12 3/8" Nylock nut
- 2 3/8" G8 Nylock nut
- 4 3/8" U-bolt
- 1 1/2" Thick Steel Spacer
- 1 1/4" Thick Steel Spacer
- 2 Urethane Bushing
- 4 Mounting Tab, round subframe connectors
- 1 Grease Fitting
- 1 Grease Packet

Bassani Exhaust Systems

Installation differences of the Bassani X-Pipe, in combination with Mustang production tolerances, makes for a wide range of X-pipe modifications for proper clearance. We have found that some cars can require almost no modification to the X-pipe, whereas others can require a bit of cutting and welding.

1. First determine if any modification is needed by trying to bolt your X-pipe in the car after the MM Torque-arm is installed. Most 1994 and newer cars will require only minor modifications.
2. With the X-pipe bolted in, look at how the Torque-arm Crossmember sits in the crotch of the X-pipe. It should look like the photo below.

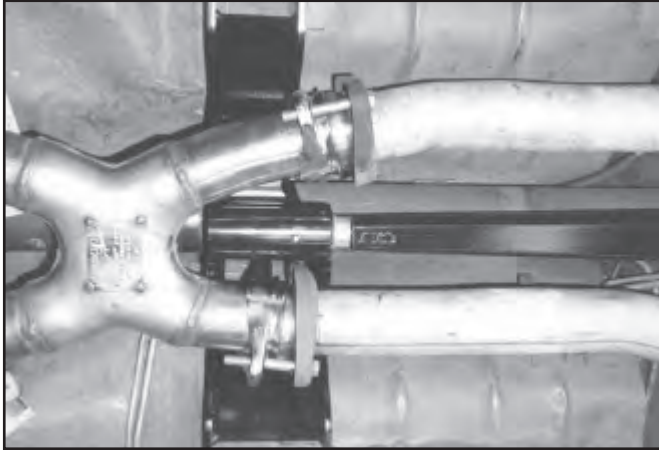

3. Minor modifications include grinding and hammering inside welds on the X-pipe seam and/or beveling the front corner of the crossmember receptacle tube (shown below). **Do Not** grind anywhere else on the Torque-arm Crossmember! Our Crossmember is not engineered for extra material loss!

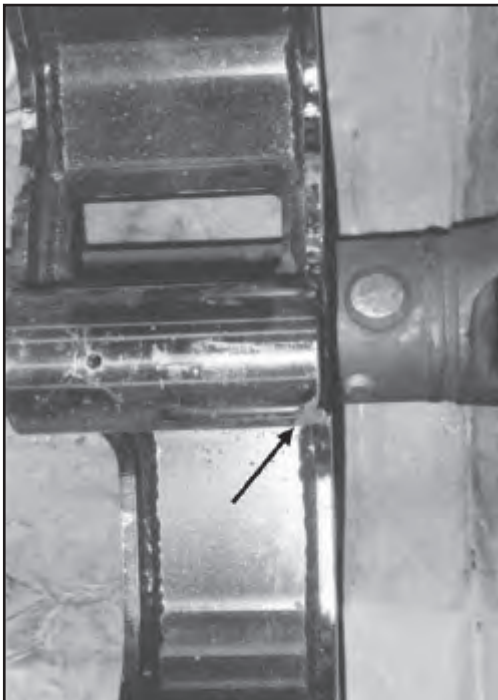

Major Modifications for the Bassani Smog-Legal X-Pipe

On 1993 and earlier cars, the X-pipe will almost always be offset toward the passenger side of the car. For the smog-legal X-pipe, major modifications include cutting the drivers side tube of the X-pipe and shortening it to allow the X-pipe to swing toward the driver's side of the car.

1. First carefully cut the exhaust hangers off of the tubes. Do not throw them out - they will be welded back on later.

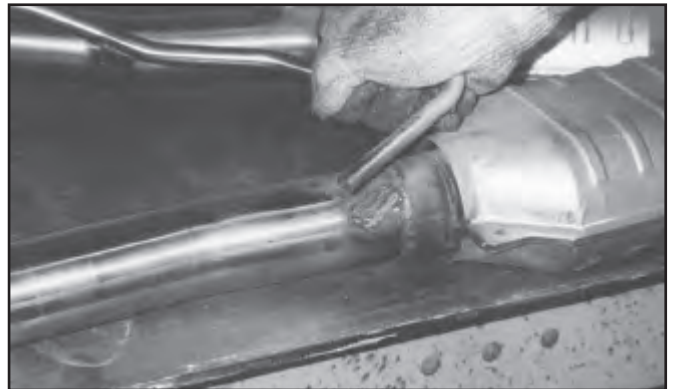

2. Cut the driver's side tube on the front side of the catalytic converter, but on the back side of the weld (closer to the cat) - see photo below.

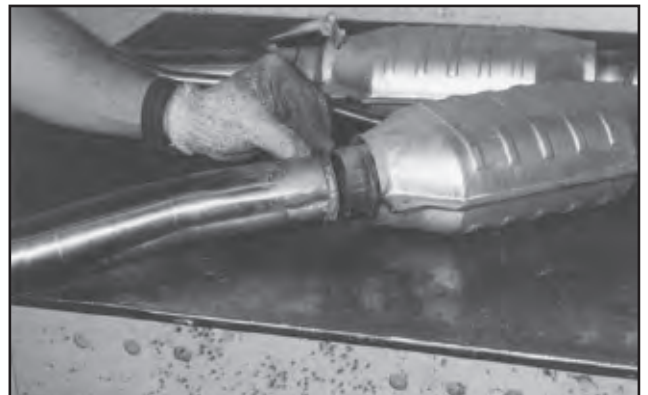

3. Remove the short section of tube remaining in the catalytic converter.
4. Grind the weld off of the tube so the tube can slide inside of the catalytic converter.

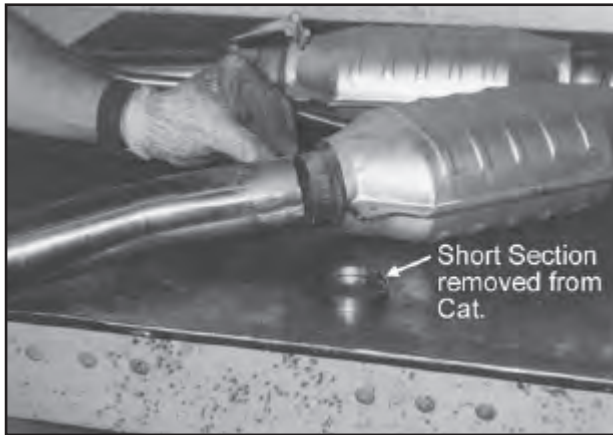

5. Using a floor jack or transmission jack, raise the X-pipe up towards the bottom of the car until it is at its original height.
6. With the passenger side snug to the header, but loose enough to swing side to side, swing the X-pipe toward the drivers side until clearance to the Torque-arm Crossmember is optimum (see below). As you do this, you need to insert the drivers side tube in to the catalytic converter where the original weld was cut off.

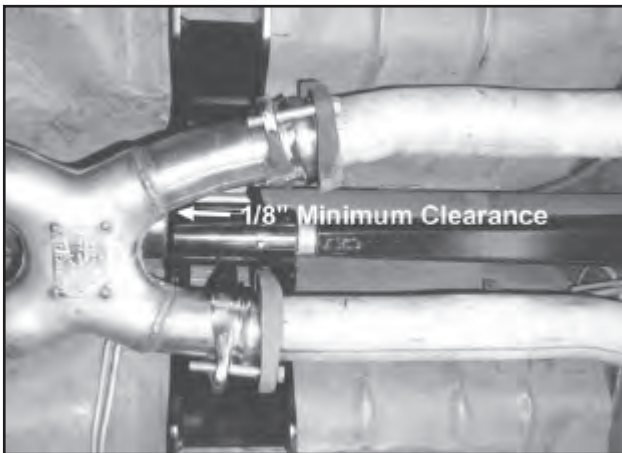

7. Snug the bolts at the passenger side header collector to hold the X-pipe in place.
8. Check the clocking of the drivers side tube up around the transmission and front K-member to make sure clearance is optimum. Snug the header collector bolts on the drivers side.
9. Check the entire X-pipe and make sure it is level under the car as viewed from the front and rear of the car.
10. Once satisfied that everything is in proper position, weld the driver's side tube back into the catalytic

converter.

11. With all the exhaust bolted together and exhaust hangers engaged in the transmission mount, weld the hangers back onto the exhaust.

Major Modifications for the Bassani Off-Road X-Pipe

1. Carefully cut the drivers side tube off behind the weld on the X-pipe and cut the cross brace on the driver side.

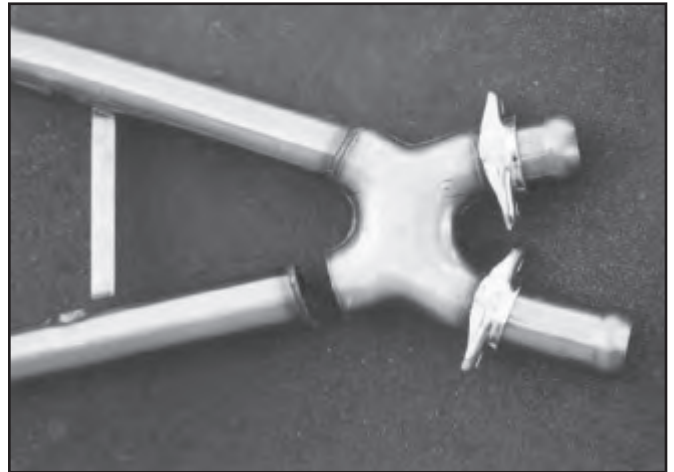

2. Remove the short section of tube remaining in the X-pipe.

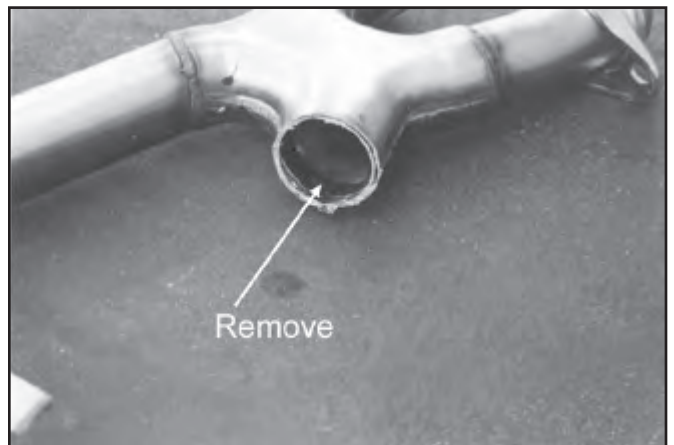

3. Grind the weld off of the drivers side tube so the tube can slide inside of the x-section.

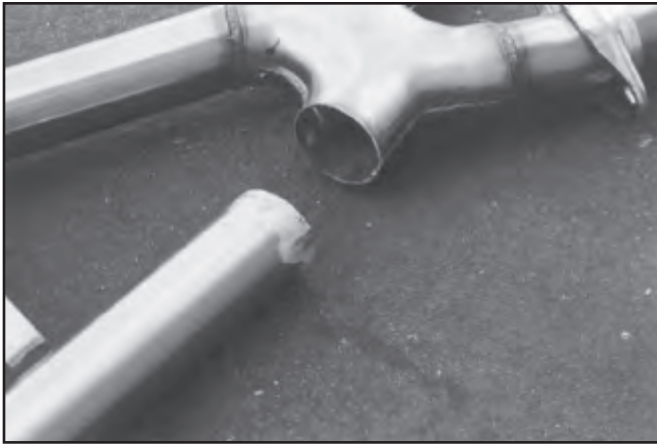

4. Carefully cut the exhaust hanger off of the tubes. Do not throw them out as they will be welded back on later.
5. Using a floor jack or transmission jack, raise the X-pipe up towards the bottom of the car until it is at its original height.
6. With the passenger side snug to the header, but loose enough to swing side to side, swing the X-pipe toward the drivers side until clearance to the Torque-arm Crossmember is optimum (see below). As you do this, you need to insert the drivers side tube into the x-section where the original weld was cut off.

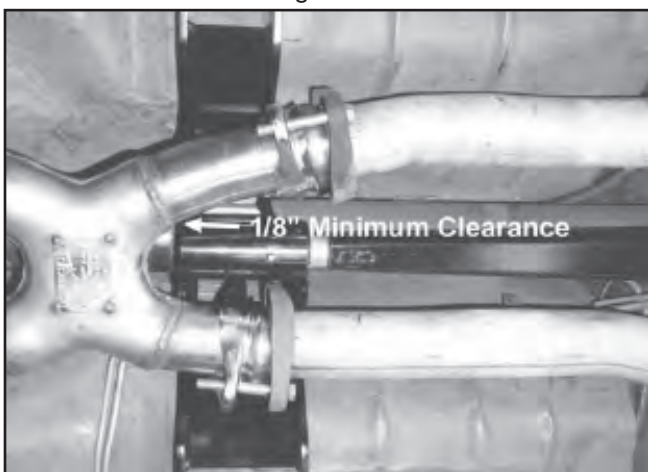

7. Snug the bolts at the passenger side header collector to hold the X-pipe in place.
8. Check the clocking of the drivers side tube up around the transmission and front K-member to make sure clearance is optimum. Snug the header collector bolts on the drivers side.
9. Check the entire X-pipe and make sure it is level under the car as viewed from the front and rear of the car.
10. Once satisfied that everything is in proper position, weld the drivers side tube back into the x-section.
11. With the exhaust all bolted together, and the exhaust hanger engaged in the transmission mount, weld the hangers back onto the exhaust.