

## Racing Upper Shock Mount Base Kit (MMSM-12)

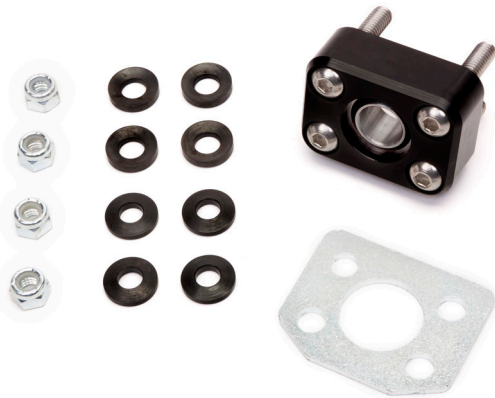

Congratulations on purchasing Maximum Motorsports' MMSM-12 Racing Upper Shock Mount Base Kit. This unique product provides a spherical bearing upper mount to securely locate one shock top. (*Two are required per car.*)

Eliminating the vertical deflection allowed by standard rubber upper bushings increases the overall damping effectiveness of the shock. The spherical bearings' freedom of movement also minimizes side loading on the shock shaft caused by rubber bushings, decreasing friction and improving the effectiveness of the shock valving.

This base kit requires the purchase or fabrication of spacers to allow the installation of a shock. Please check the MMSM-12 product page on the MM website for available spacer kits.

*Read all instructions before beginning work. Following instructions in the proper sequence will ensure the best and easiest installation.*

### Required Tools

- Standard assortment of hand tools
- Floor jack & 4 jack stands
- Drill with 11/32" drill bit

### Installation Time

Shop: 1.5 Hours

Home Mechanic: 3 Hours

### Supplemental Installation Notes

- This kit is manufactured for shocks that have a 5/8" diameter or smaller shaft.
- The MMCO-21 Coil-over Kit is designed to mount a MMD-RC0xxxx shock directly to the MMSM-12 and includes the required spacers.

### This Kit Contains

Description	QTY
Racing Upper Shock Mount	1
5/16 spherical washer set	4
5/16-18 G5 Nylock nut	4

**WARNING:** Reversing installation of the racing upper shock mount isn't easy. Because of the shock tower's drilled holes, it will be too weak if you run the shock in stock configuration without welding the holes closed.

**WARNING:** Letting the axle drop or hang past what the shocks allow can result in damage to brake lines and bushings in the suspension.

### Component Identification

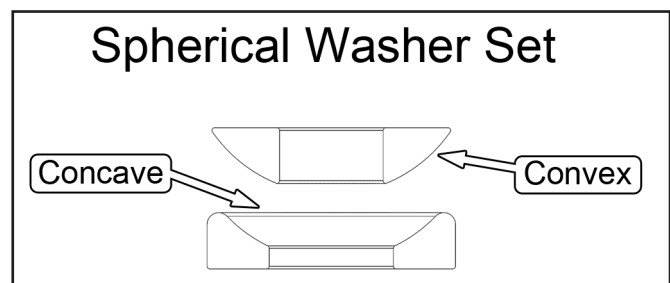

## Vehicle Preparation

1. If installing this kit in conjunction with an MMCO-21 Rear Coil-over Kit, follow the MMCO-21 instructions until they reach the point of installing the MMSM-12 Racing Upper Shock Mount. Then proceed to the Racing Upper Shock Mount Installation section of these instructions (starting at Step 5).
2. Block the front wheels, jack up the rear, and support it with jack stands under the rocker panel pinch welds. With the shocks just short of full extension, support the axle on jack stands. Remove the rear wheels.
3. From inside the car, remove the shock top nut, thrust washer, and shock rubber isolator.
4. Remove the bottom shock bolt from the lower shock mount. Save the lower shock bolt and nut. Remove the shock from the car.

## Racing Upper Shock Mount Installation

5. Check that the hole in the rear shock tower is at least 1" diameter. The size of this hole varies greatly, and it may need to be enlarged. Use a round file, die grinder, or Uni-Bit for this operation.
6. Set the steel doubler plate on top of the rear shock tower with the two angled corners positioned toward the center of the car. Center the large center hole of the plate over the hole in the chassis where the shock comes through. Align the doubler plate so it's parallel to the rear inner wheel well housing. You may need to remove seam sealer from the mounting area.



7. Mark the position of the 4 mounting holes onto the shock tower using a center punch. Remove the doubler plate.
8. Drill four pilot holes using a 1/8" drill bit.
9. Enlarge the four pilot holes to the final size of 11/32" and deburr the holes.
10. Set the racing shock mount into place, with the four mounting bolts protruding down through the four new holes in the shock tower.
11. From underneath the shock tower, place a doubler plate over the 4 mounting bolts and push it up against the shock tower. The angled corners are positioned toward the center of the car.
12. Place a spherical washer set on each bolt, convex sides first (see image below), followed by a Nylock nut.

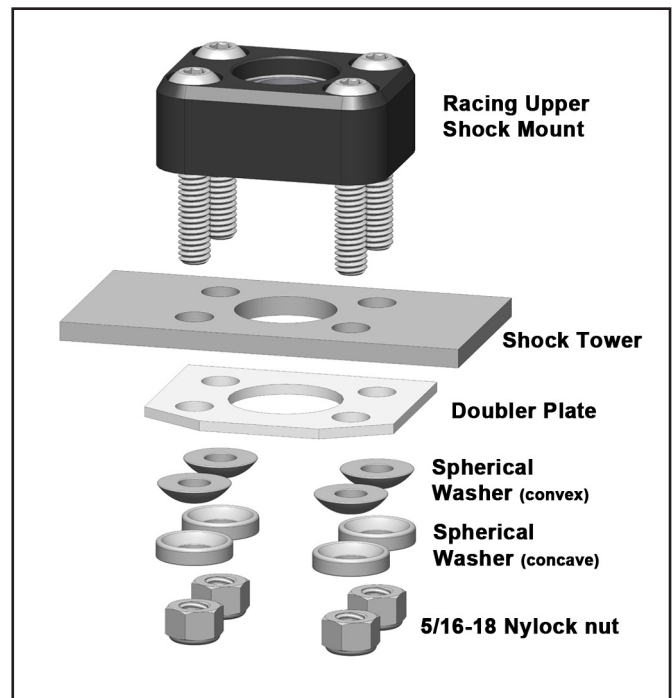

13. Torque each Nylock nut to 19 lb-ft.

## Shock Installation

The installation of the racing upper shock mount is complete. If installing a MMCO-21 Rear Coil-over Kit, return to those instructions now to complete the shock installation.