

MM Caster/Camber Plates, 1990-93 (MMCC9093)



IMPORTANT: The bearing used in our Caster/Camber Plates is swaged together with Teflon® in between the race and ball. This provides a very tight tolerance fit that prevents dirt from entering the bearing. The Teflon® reduces friction and minimizes wear over the lifespan of the bearing. The tight tolerances will not allow easy movement of the bearing center by hand. If the center of the bearing must be rotated, use the strut shaft as a lever to facilitate movement. **DO NOT ATTEMPT TO LUBRICATE THE BEARING.** Any oil or grease will attract dirt and damage the Teflon®, voiding the warranty.

Read all instructions before beginning work. Following instructions in the proper sequence will ensure the best and easiest installation.

Thank you for purchasing Maximum Motorsports' Caster/Camber Plates, now with a lifetime warranty against spherical bearing failure and plate failure. That's right — If you wear it out, or break it while driving, we will replace that component for free. This warranty applies to the original retail purchaser of all genuine MM Caster/Camber Plates purchased after January of 2003.

Our Caster/Camber Plates are designed to maximize the performance of your Mustang's front suspension. You will find many features that set our Caster/Camber Plates apart from the rest:

- The camber adjustment slots in the MM plates, when used in conjunction with the factory camber adjustment slots, allow the widest range of camber adjustment possible.
- High grade Teflon® lined spherical bearings are used at the strut top mounting point.
- Plates are spaced well above the strut tower top to allow the bump travel to be restored for lowered cars.
- High grade alloy steel allows our plates to be thin and fatigue proof.

The latest version, high quality COLOR instructions are available online: www.maximummotorsports.com

Installation Time: 2 hours

Supplemental Requirements:

When using MM branded struts without a coil-over kit, a Service-6 dust boot kit must be purchased, as the MM struts do not ship with dust boots.

Tools Required

- Standard assortment of hand tools
- 9/16" socket
- 3/4" socket
- Torque wrench
- 1/8" Drill bit
- Drill
- Floor jack and 2 jack stands

This Kit Includes

- | | |
|----|--------------------------------|
| 12 | 1/2" SAE Flat Washer, G8 |
| 4 | 3/8" SAE Flat Washer, G8 |
| 4 | 3/8-16 Nylock Nut |
| 6 | 1/2-13 Nylock Nut |
| 2 | Bumpstop |
| 2 | 14" Black zip-tie |
| 2 | Bearing Plate |
| 2 | Bottom Plate |
| 1 | Main Plate, Passenger |
| 1 | Main Plate, Driver |
| 4 | Strut Shaft Spacer, 0.48" Long |
| 4 | Strut Shaft Spacer, 0.24" Long |
| 6 | 1/2" ID Main Plate Spacer |

Component Identification

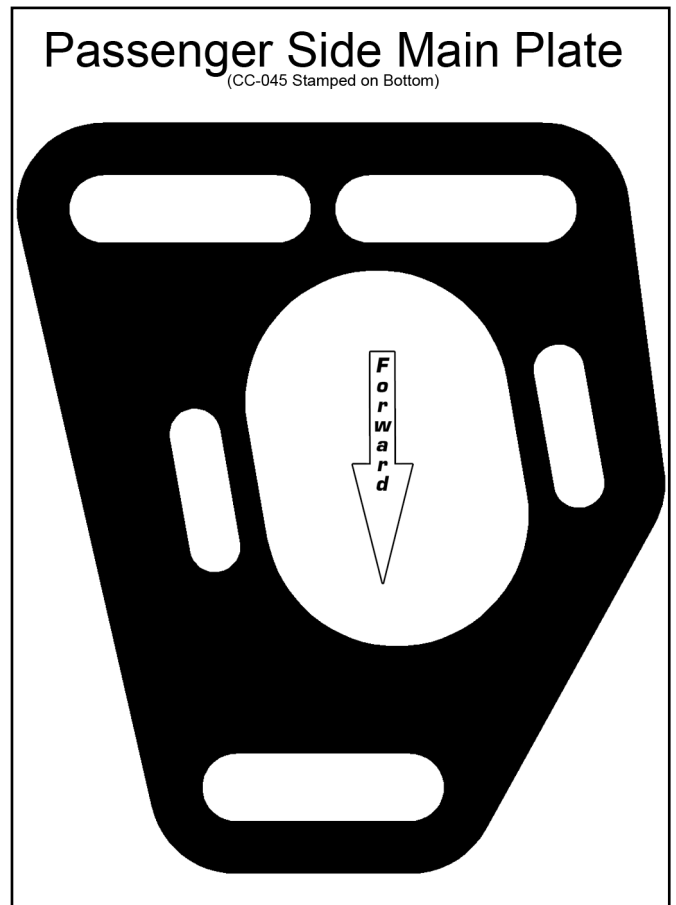
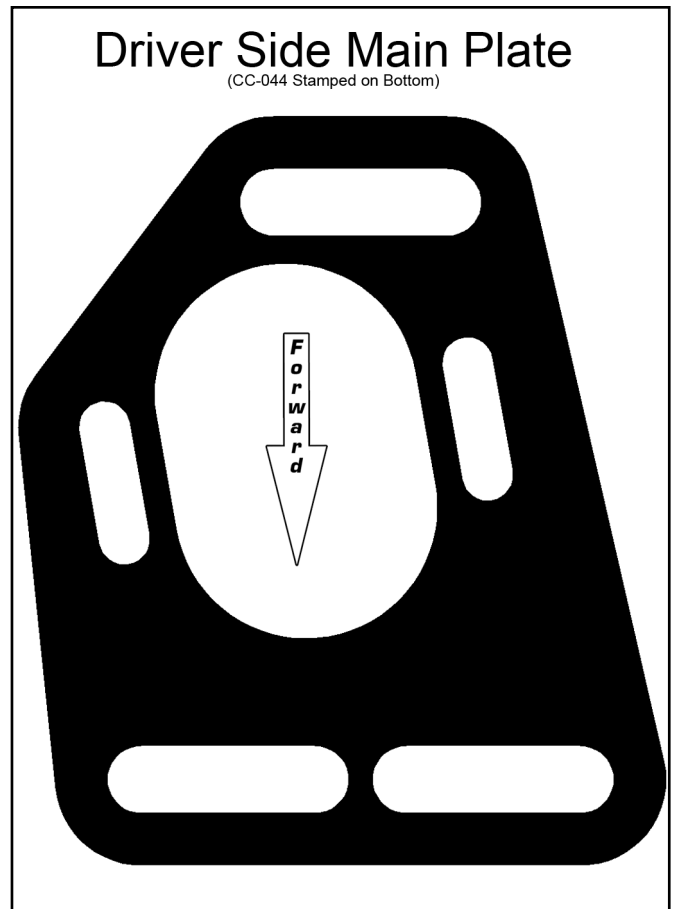
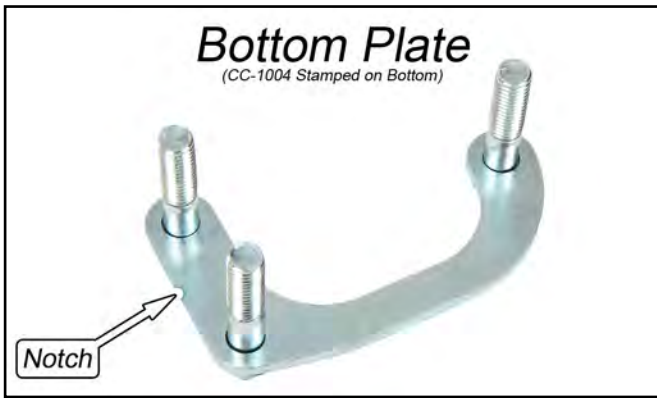

Factory Strut Mount Removal

1. Jack up front of vehicle and place firmly on jack stands.
2. Remove front wheels.
3. Disconnect the front swaybar endlinks.
4. Place a floor jack under the control arm ball joint and jack up until slightly loaded.

5. Remove the strut shaft retaining nut. If reusing the struts, save the nut, it will be used later.

NOTE: It may be easier to initially loosen the nut with air tools.

6. Remove the three nuts that hold the factory strut mount in place. If present, drill and remove the pop rivet that retains the top mounting plate. Discard the top mounting plate.
7. Carefully lower the jack to bring the strut shaft down through the strut tower center hole, but do not completely unload the jack: the spring may become dislodged, causing injury and/or damage.
8. From the top of the strut tower, remove and discard the thrust washer, the top rubber bushing and the crush sleeve from the strut shaft. **(Figure 1)**

9. Collapse the strut shaft down into the strut body far enough to remove the factory bottom plate and dust boot assembly. Discard the factory bottom plate. Save the dust boot. **(Figure 1)**

NOTE: With some struts, it may be easier to remove the strut from the spindle instead of collapsing the strut shaft into the strut body.

10. Remove and discard the OEM bumpstop from the strut shaft. **(Figure 1)**
11. Cut and remove the metal band clamp securing the plastic dust boot to the bump cap. Separate the dust boot from the bump cap. Discard the bump cap, but save the dust boot. **(Figure 1)**

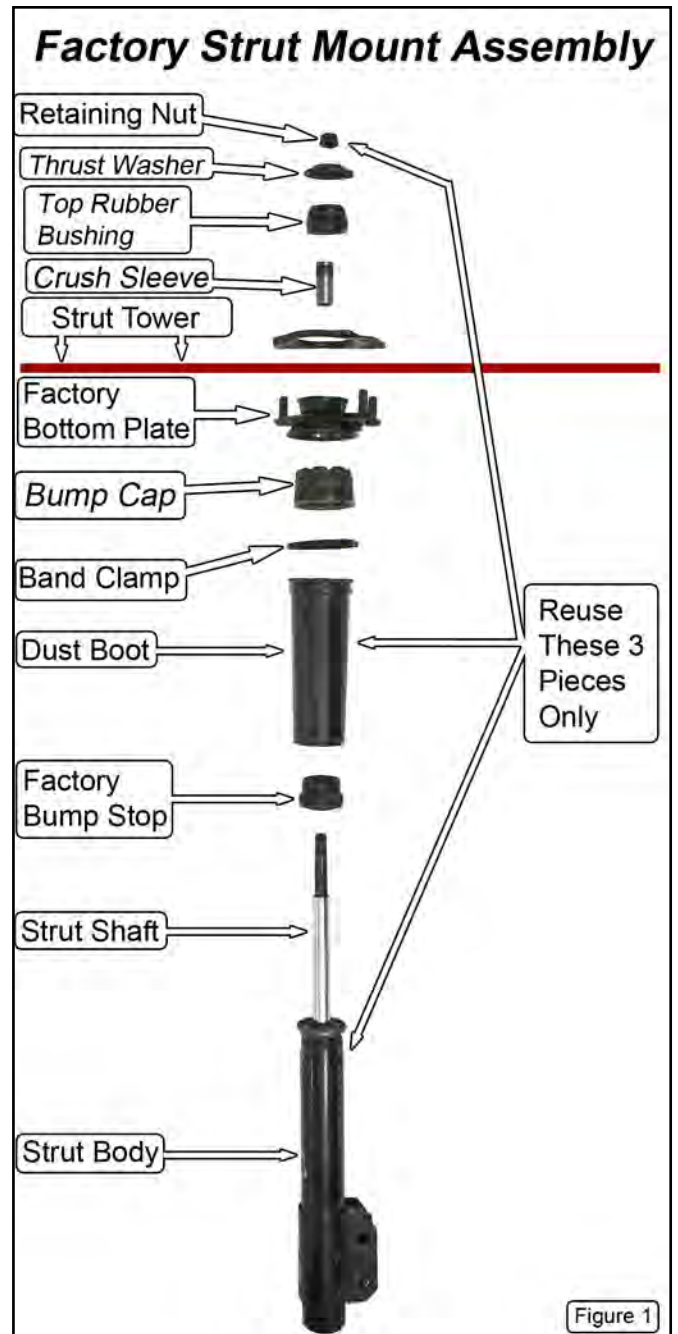

MM Camber Plate Installation

NOTE: The factory dust boot and provided Bumpstop are NOT used in coil-over applications. Refer to the coil-over installation instructions for more information.

NOTE: If using MM or Bilstein struts, the provided Bumpstops are not used. MM and Bilstein struts have internal bumpstops.

NOTE: If using MM struts without a coil-over kit, you must order a **Service-6** dust boot replacement kit from Maximum Motorsports. Failure to use a dust boot will void your strut warranty.

12. Attach the provided Bumpstop and dust boot to one another. Slide the assembly over the strut shaft with the conical portion facing upwards. (Figure 2)

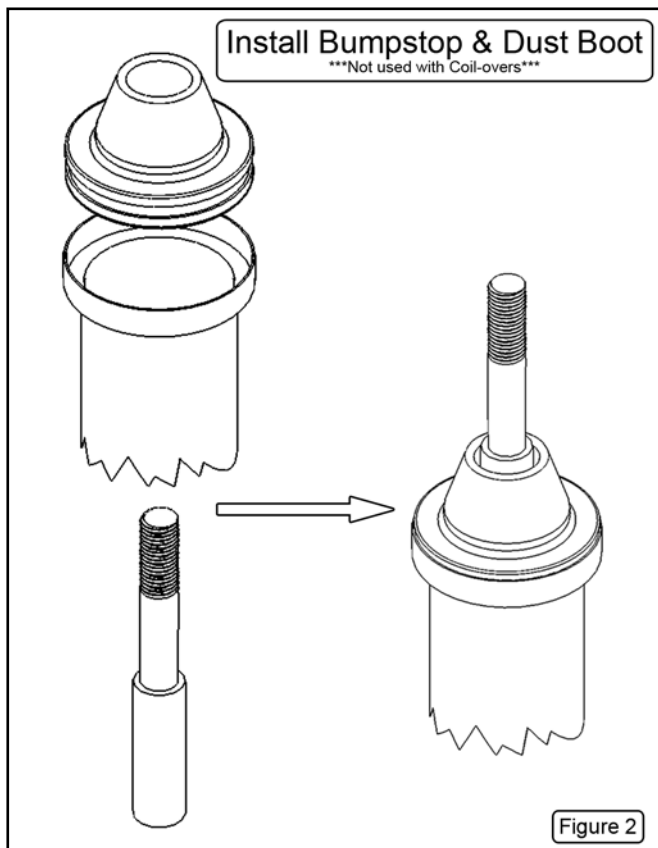

13. Pull the bumpstop/dust boot assembly down the strut shaft slightly so that it will not interfere with the strut tower while the alignment is being performed. (Figure 3)

14. Secure the bumpstop to the dust boot with one of the provided zip-ties. (Figure 3)

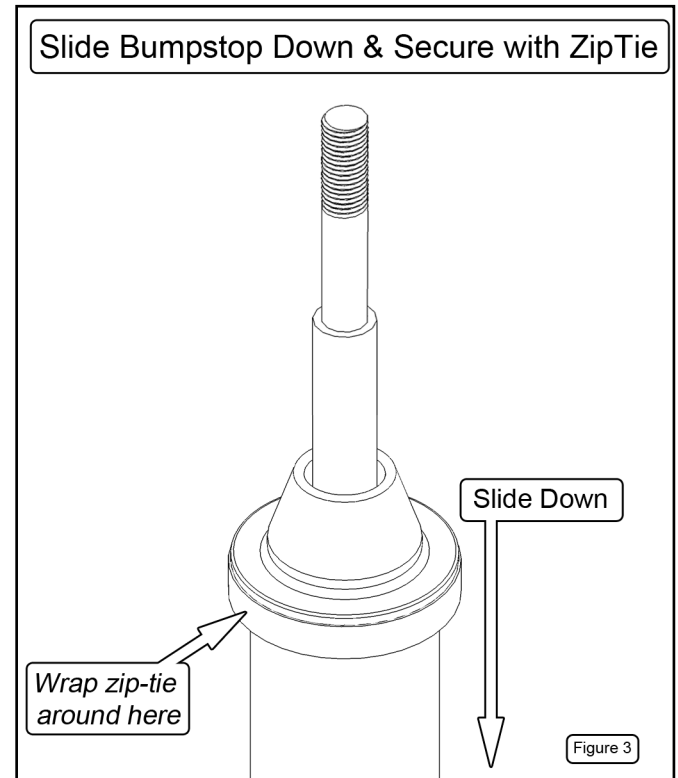

15. Identify the driver's side and passenger's side Main Plates. The large center slot will be biased towards the rear of the plates.
16. Install a Bearing Plate onto both Main Plates so that the MM logo faces towards the front of the vehicle. Failure to orient the Bearing Plates correctly will limit your range of adjustment.

NOTE: If no sticker is present, the front of the Bearing Plate can be determined as shown below. The bearing is offset rearwards when looking down on the Bearing Plate. (Figure 4)

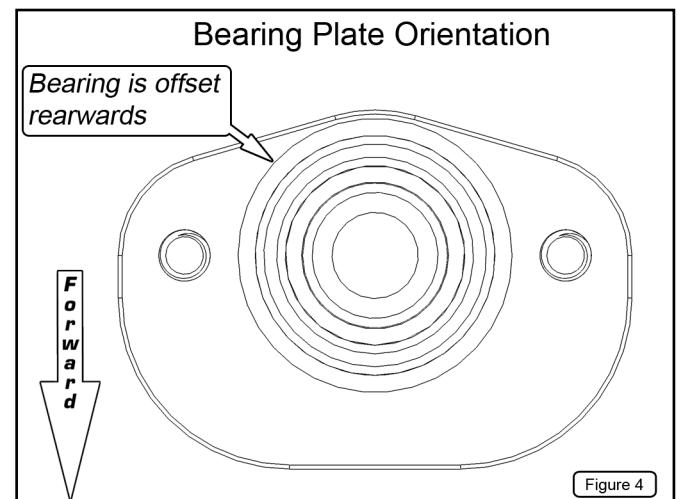

17. Place a 3/8" washer over each stud of the Bearing Plate, and secure with a 3/8" Nylock nut. Do not tighten the nuts at this time. **(Figure 5)**

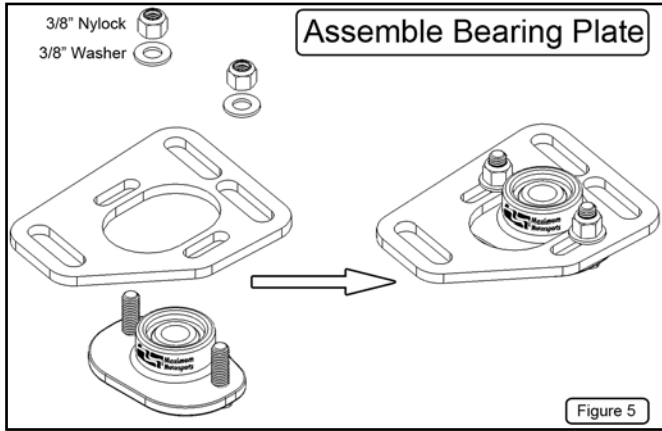

18. Install the MM Bottom Plates beneath the strut towers with the 1/2" studs protruding upwards through the factory mounting slots and hole. Make sure the Bottom Plate slides freely in the adjusting slots of the strut tower. If not, file the slots until they do. **(Figure 6)**

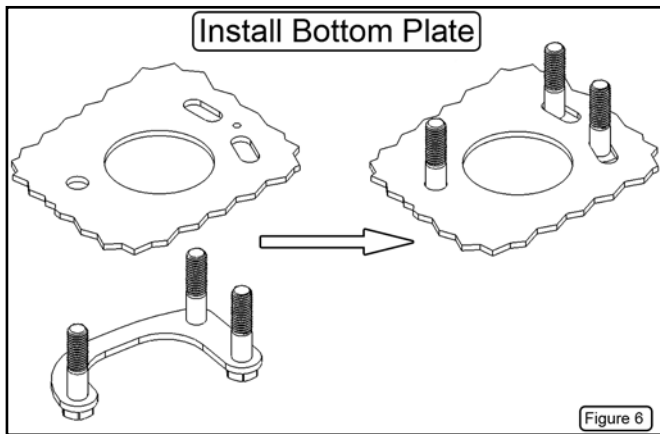

19. Install 1/2" washers over the 1/2" studs of the Bottom Plate. These washers will rest directly on top of the car's strut tower. **(Figure 7)**

20. Install the 1/2" ID Main Plate Spacers over the 1/2" studs of the Bottom Plate. **(Figure 7)**

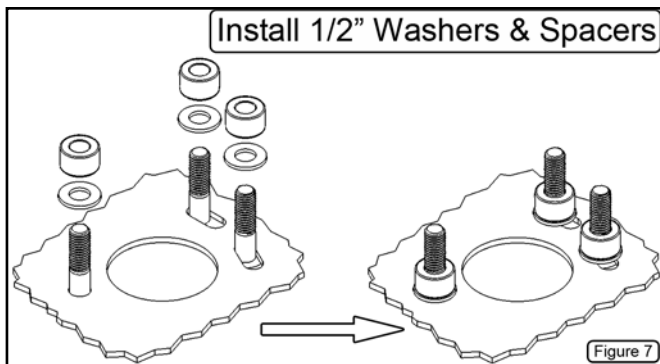

21. Install the appropriate Main Plate/Bearing Plate assembly over the studs of the Bottom Plate on the car. **(Figure 8)**

22. Install the 1/2" washers and the 1/2" Nylock nuts on the studs of the Bottom Plate. **(Figure 8)**

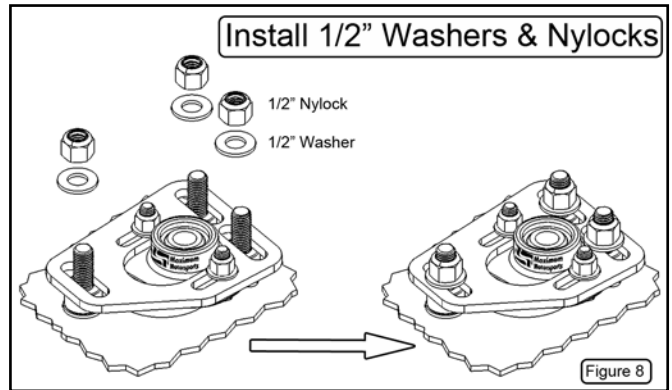

23. Place one 0.48" and one 0.24" Strut Shaft Spacer onto each strut shaft. Compress the strut shaft into the strut body while quickly moving the strut underneath the fender, then let the strut shaft extend up through the Bearing Plate. **(Figure 9)**

NOTE: For MM Coil-over applications, consult your Coil-over Instructions for correct spacer arrangement.

NOTE: If your struts are equipped with an adjuster on the top of the shaft, carefully close the hood to check for interference between the top of the strut shaft and the hood.

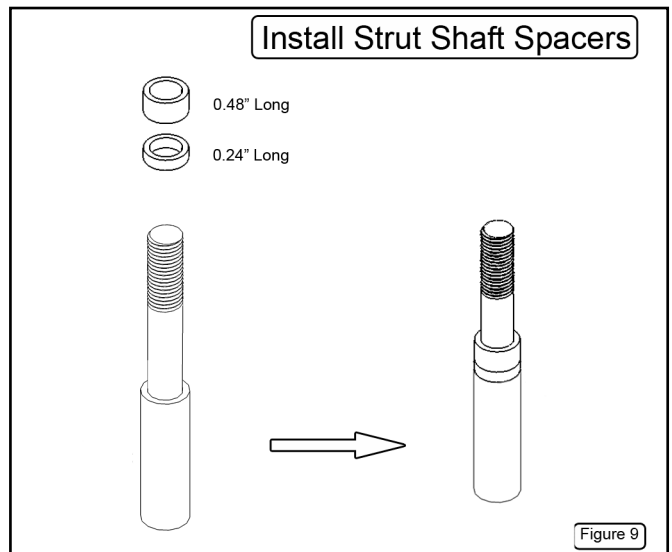

24. Place one 0.48" and one 0.24" Strut Shaft Spacer onto each strut shaft, above the spherical bearing. **(Figure 10)**

25. Reinstall the strut shaft retaining nut and hand tighten. **(Figure 10)**

IMPORTANT - At least one spacer above the spherical bearing is required to allow proper movement. Failure to do so will result in limited bearing articulation and possible damage to the bearing and/or the strut!

NOTE: Some aftermarket struts use an English strut shaft diameter that is smaller than the 16mm OEM strut shaft diameter. A cylindrical metal shim should be fabricated and installed between the strut shaft and the spherical bearing to reduce the possibility of movement and noise.

NOTE: Various strut manufacturers have unique lengths for the top threaded portion of the strut shaft. You may need to omit a spacer to fully engage the nut on the strut shaft.

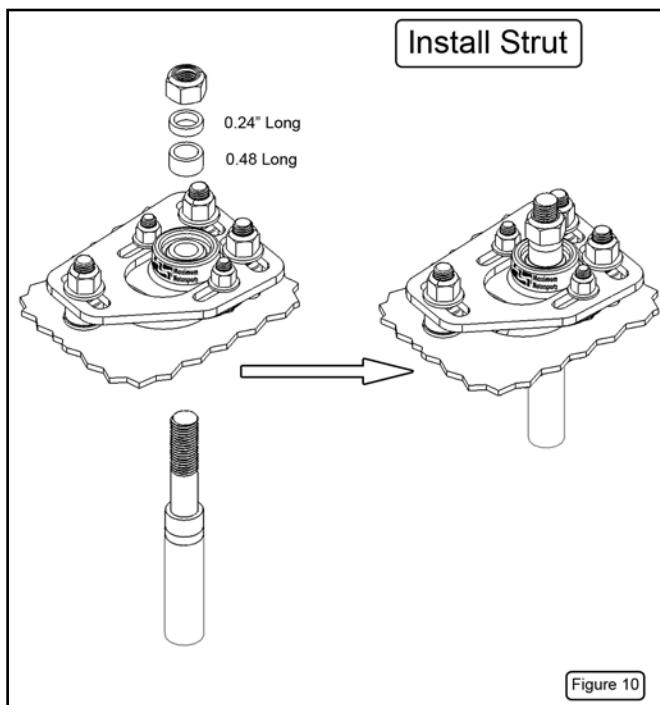

26. Temporarily tighten the caster/camber plate adjusting nuts.

3/8" Nylock: 32 lb-ft

1/2" Nylock: 65 lb-ft

27. Reconnect the front swaybar endlinks.

28. Reinstall wheels and carefully lower the vehicle to the ground.

29. Torque the lug nuts to factory specification.

30. Torque the strut shaft retaining nut to your strut manufacturer's specification. Failure to properly torque the nut will allow the strut shaft to move up and down in the bearing, causing damage and various unpleasant noises.

31. The car must now have a proper front-end alignment. While some do-it-yourselfers perform their own alignments at home with the help of a Maximum Motorsports Camber Gauge (Part# **MMT-3**), many people elect to take their Mustang to a professional alignment shop. On the following page is important information to pass on to the alignment technician.

Maximum Motorsports offers the MMT-3 Camber Gauge for about the same cost as a professional alignment. The MMT-3 comes complete with detailed instructions on how to properly measure and adjust caster and camber.



MM Caster/Camber Plate Alignment Guide, 1979-93

Important Notes for Alignment

- Do NOT over-torque the adjustment bolts. The proper torque values are:
 - 3/8" Nylock nut (small nut): 32 lb-ft
 - 1/2" Nylock nut (large nut): 65 lb-ft
- The large center hole of the strut tower can cause interference with the strut shaft when the camber or caster is adjusted towards the limit of travel. If you are adjusting towards the extreme limits of camber and/or caster, check the clearance between the strut shaft and the edge of the large center hole. Check not only with the wheels pointed straight ahead, but also while turning the steering from lock to lock. You may enlarge the center hole with a file or die grinder to provide more clearance.
- When applicable, the bumpstop must be pulled down, away from the strut tower before setting the alignment. The top of the bumpstop will interfere with the strut tower and limit the adjustment range.
- Caster and camber settings change the strut shaft's position relative to the hood. Double check hood clearance with the car on the ground, while turning the steering from full lock to full lock.
- With MM or Bilstein Struts, extra camber adjustment can be gained by loosening the strut to spindle mounting bolts and either pull the strut outwards for less negative camber, or push it inwards for more negative camber.
- Additional camber adjustment can be achieved by sliding the bottom plates inboard or outboard in the slots on the strut tower.

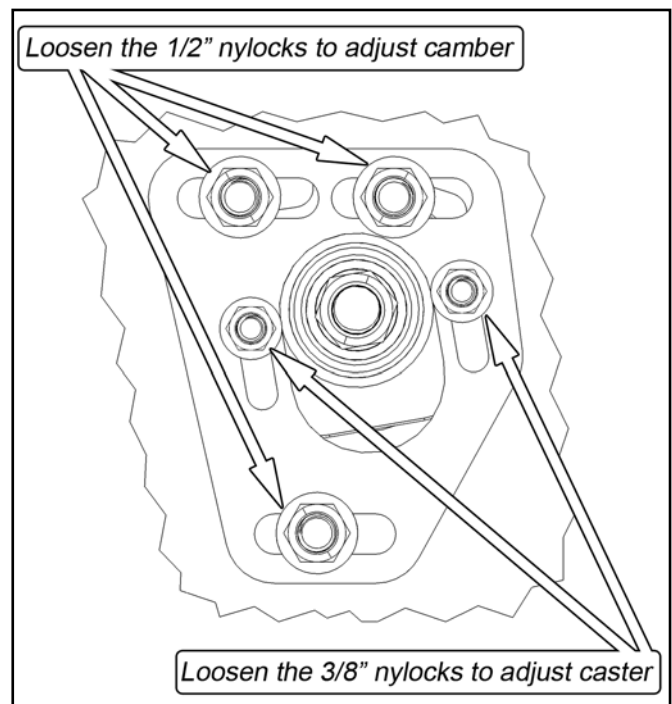
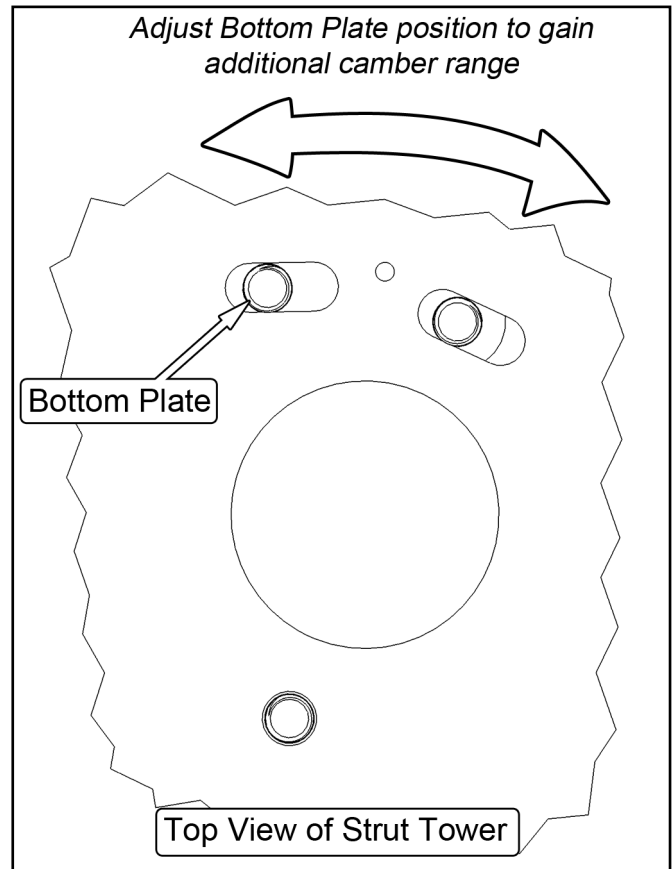

Caster Setting

Our recommendation for the caster setting depends on which K-member is used:

	Caster Setting	
	Street Car	***Race Car***
Stock K-member	3° - 4°	Most Positive
MM K-member	4°	6° - 8°

NOTE: Bumpsteer MUST be adjusted when running more than 6° of caster.

It is typical for alignment shops to set the passenger side caster to a slightly greater amount than the driver side setting. For street-driven cars, a difference of 0.25° to 0.5° will help counter the effect of road crown, and prevent the car from pulling towards the right on most roads.

Many variables affect the caster reading. If the car has any rake, the measured amount of caster will be less than if the car was level. Changes in ride height will affect the measured amount of caster. Different technicians using different alignment equipment will indicate different caster values. Unlike camber, the number of degrees that caster is set to does not have to be exact. As long as caster is in the desired range, and the difference from one side to the other is not greater than 0.5°, it is fine.

Camber Setting

Camber Setting	
Street Car	0.75° negative, +/- 0.25°
Race Car	3.00° negative, varies by track

Toe Setting

Toe Settings	
Street Car	0.5° Total toe-in
Race Car	0.5° Total toe-out, varies by driver

Remember that any time any change is made to the camber setting, the toe setting will be affected, and must be readjusted.

It is a good idea to always keep a record of the alignment settings. Inspect the tires frequently for uneven tread wear patterns. If uneven tire wear becomes evident, have the alignment adjusted. With a record of the previous alignment it will be easier to diagnose the problem and make alignment adjustments to improve tire wear.

Bumpsteer

Bumpsteer is the term for the toe setting of a wheel changing as the suspension moves up and down over bumps, or with body roll while cornering.

There is a widespread myth that the tie-rod should be kept parallel to the ground to avoid bumpsteer. THIS IS NOT TRUE! What IS required is for the tie-rod to be kept parallel to the lower control arm. That way, as the suspension moves, the arc of the ball joint and the arc of the tie-rod end do not transfer any steering input to the spindle. As the car is lowered, the tie-rod end and the lower control arm move together, staying parallel. If offset steering rack bushings are installed on a stock-geometry K-member, the tie-rod end and the lower control arm will no longer be parallel. Installing offset rack bushings will cause a bumpsteer problem.

Ford engineers have actually done a very good job at minimizing bumpsteer for a typical street-driven car. Specifically, the bumpsteer was designed to cause the front wheels to toe out during bump. This is a roll understeer condition; the outside loaded tire will turn to the outside of a corner as the body rolls. A car that has a basic tendency towards understeer is more stable and predictable. That predictability makes for a safer street car.

Competition cars using stock K-member geometry can benefit by fine-tuning the amount of bumpsteer with an adjustable tie-rod end kit. The MM Adjustable Tie-rod End Kits provide an assortment of spacers, in .015" increments, to help position the tie-rod end at exactly the correct height. Adjusting bumpsteer on a particular Mustang also allows correcting for individual differences in suspension geometry caused by production tolerances.